



**STRONG PARTNERS.
TOUGH TRUCKS.™**



H135-155FT SERIES TECHNICAL GUIDE

WWW.HYSTER.COM

> H135-155FT DIMENSIONS

Circled dimensions correspond to the line numbers on the tabulated chart inside the Technical Guide. Dimensions are in inches (mm).

| Seat Type | Standard OHG* | Optional Cab* |
|------------------------|---------------|---------------|
| Non-Suspension | 38.2 (971.2) | 38.2 (971.2) |
| Full-Suspension | 38.0 (965.2) | 38.0 (965.2) |
| Swivel Full-Suspension | 38.0 (965.2) | 38.0 (965.2) |

Seat in depressed position*

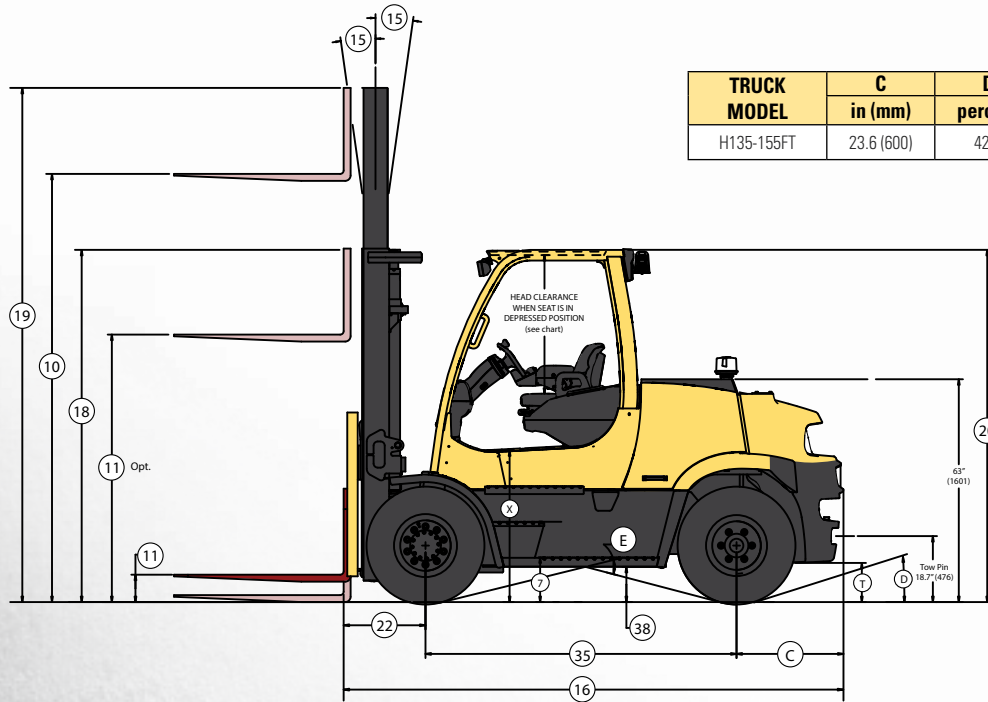
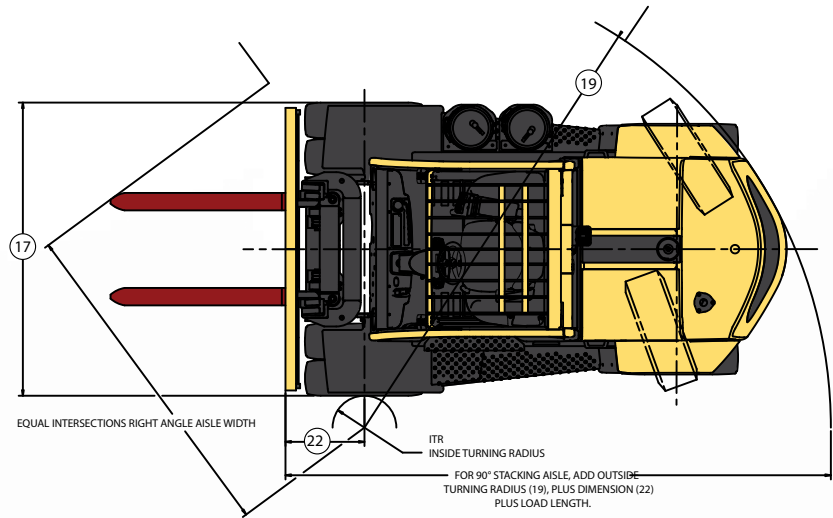

| TRUCK MODEL | C | D | E | T | X |
|-------------|------------|---------|---------|-----------|------------|
| | in (mm) | percent | degrees | in (mm) | in (mm) |
| H135-155FT | 23.6 (600) | 42% | 25 | 6.9 (177) | 33.2 (844) |

| STANDARD LIFT SPECIFICATIONS | | | | | |
|--|------------------------|--|---|---------------------------------|-----------------------------------|
| Maximum Fork Height (TOF) † | Overall Lowered Height | Overall Extended Height w/ Load Backrest | Overall Extended Height w/o Load Backrest | Free-Lift (TOF) w/Load Backrest | Free-Lift (TOF) w/o Load Backrest |
| in (mm) | in (mm) | in (mm) | in (mm) | in (mm) | in (mm) |
| 2-STAGE LIMITED FREE-LIFT (LFL) VISTA™ MAST | | | | | |
| 118 (3000) | 100 (2540) | 172 (4354) | 166 (4195) | 6 (160) | 6 (160) |
| 133 (3400) | 108 (2740) | 188 (4754) | 181 (4595) | 6 (160) | 6 (160) |
| 173 (4400) | 128 (3240) | 227 (5754) | 221 (5595) | 6 (160) | 6 (160) |
| 212 (5400) | 148 (3740) | 266 (6754) | 260 (6595) | 6 (160) | 6 (160) |
| 3-STAGE FULL FREE-LIFT (FFL) VISTA™ MAST | | | | | |
| 185 (4700) | 102 (2570) | 239 (6054) | 230 (5830) | 47 (1216) | 56 (1440) |
| 220 (5600) | 113 (2870) | 274 (6954) | 265 (6730) | 59 (1516) | 68 (1740) |
| 244 (6200) | 123 (3120) | 298 (7554) | 289 (7330) | 69 (1766) | 78 (1990) |

† Lift heights over 212" (5400 mm) maximum fork height are considered highlifts and require reduced capacity and restricted back tilt.

H135-155FT SPECIFICATIONS



| GENERAL | | Hyster H135FT | | | Hyster H155FT | | |
|---------|---|-----------------------------------|-------------------------|-------------------------|---------------------------------|-------------------------|-------------------------|
| Engine | | PSI 4.3L | Kubota 3.8L DOC | Kubota 3.8L High Output | PSI 4.3L | Kubota 3.8L DOC | Kubota 3.8L High Output |
| 1 | Manufacturer | Hyster | | | Hyster | | |
| 2 | Model | H135FT | | | H155FT | | |
| 3 | Rated Capacity | 13,500 (6,000) | | | 15,500 (7,000) | | |
| 4 | Load Center, Distance | 24 (610) | | | 24 (610) | | |
| 5 | Engine/Power Type - Gasoline, LPG, Diesel | LPG | Diesel | | LPG | Diesel | |
| 6 | Operator Type | Seated Rider | | | Seated Rider | | |
| 7 | Step Height | 12.6 (321) | | | 12.6 (321) | | |
| 8 | Tire Type - Cushion, Solid, Pneumatic | Pneumatic | | | Pneumatic | | |
| 9a | Wheels, Number - Front/Rear (X = driven) | 4X/2 | | | 4X/2 | | |
| 9b | Track Width, Front / Rear | 72.7 (1846) / 60.5 (1535) | | | 72.7 (1846) / 60.5 (1535) | | |
| 10 | Lift Height, w/LBR (TOF) (Rounded Down) | 212 (5400) | | | 212 (5400) | | |
| 11a | Std Free Lift Height (TOF) (Rounded Down) | 6 (160) | | | 6 (160) | | |
| 11b | Opt Full Free Lift w/ LBR (TOF) (Rounded Down) | 95 (2416) | | | 95 (2416) | | |
| 11c | Opt Full Free Lift w/o LBR (TOF) (Rounded Down) | 103 (2640) | | | 103 (2640) | | |
| 12 | Standard Carriage Width | 78 (1981) | | | 78 (1981) | | |
| 13 | Standard Forks, Thickness x Width x Length | 6 x 2.5 x 48 (150 x 60 x 1219) | | | 6 x 2.5 x 48 (150 x 60 x 1219) | | |
| 14a | Standard Fork Spread, Min Inside Dimensions | 6.3 (160) | | | 6.3 (160) | | |
| 14b | Standard Fork Spread, Max Outside Dimensions | 73.9 (1876) | | | 73.9 (1876) | | |
| 15 | Mast Tilt, Forward/Backward | 5 / 10 | | | 5 / 10 | | |
| 16 | Overall Length (to Face of Forks) | 141.9 (3604) | | | 144.4 (3669) | | |
| 17 | Overall Width | 82.0 (2082) | | | 82.0 (2082) | | |
| 18 | Height, Std Mast - Lowered | 148 (3740) | | | 148 (3740) | | |
| 19a | Height, Std Mast - Extended w/o LBR (Rounded Up) | 260 (6595) | | | 260 (6595) | | |
| 19b | Height, Std Mast - Extended w/ LBR (Rounded Up) | 266 (6754) | | | 266 (6754) | | |
| 20a | Height, Std Overhead Guard (High) (Rounded Up) | 100 (2531) | | | 100 (2531) | | |
| 20b | Height, Std Overhead Guard (Cab) (Rounded Up) | 101 (2549) | | | 101 (2549) | | |
| 21a | Turning Radius, Minimum Outside (OTR) | 130.7 (3320) | | | 133.4 (3388) | | |
| 21b | Turning Radius, Minimum Inside (ITR) | 9.1 (230) | | | 9.1 (230) | | |
| 22 | Length, Center of Wheels to Face of Forks | 23.7 (601) | | | 23.7 (601) | | |
| 23a | Aisle Width, Rt Angle Stack (pallet w=42in, L=48in) | 202.4 (5140) | | | 205.0 (5207) | | |
| 23a | Aisle Width, Rt Angle Stack (Add Length of Load) | 154.4 (3921) | | | 157.0 (3988) | | |
| 24 | Equal Aisle, 90-Degree Intersecting Aisle | 111.6 (2835) | | | 111.8 (2865) | | |
| 25a | Travel Spd Fwd, RL/NL w/2-spd (Fwd) Transmission | mph (km/h) 13.7/13.8 (22/22.1) | 12.6/12.7 (20.2/20.5) | | 13.6/13.8 (21.9/22.1) | 12.5/12.7 (20.2/20.4) | |
| 25b | Travel Spd Fwd, RL/NL w/3-spd (Fwd) Transmission | mph (km/h) 15.4/15.7 (24.9/25.2) | 13.7/13.8 (22/22.2) | | 15.4/15.6 (24.7/25.1) | 13.6/13.8 (21.8/22.1) | |
| 25c | Travel Spd Rev, RL/NL w/either Transmission | mph (km/h) 13.7/13.8 (22/22.1) | 12.6/12.7 (20.2/20.5) | | 13.6/13.8 (21.9/22.1) | 12.5/12.7 (20.2/20.4) | |
| 26a | Lift Speed, Standard 2-Stage LFL RL/NL | ft/min (m/s) 104/106 (.53/.54) | 94/96 (.48/.49) | | 104/106 (.53/.54) | 87/96 (.44/.49) | |
| 26b | Lift Speed, Optional 3-Stage FFL RL/NL | ft/min (m/s) 100/102 (.51/.52) | 93/93 (.47/.47) | | 100/102 (.51/.52) | 85/93 (.43/.47) | |
| 27a | Lowering Speed, Standard 2-Stage LFL RL/NL | 114/104 (.58/.53) | | | 114/104 (.58/.53) | | |
| 27b | Lowering Speed, Optional 3-Stage FFL RL/NL | 104/81 (.53/.41) | | | 104/81 (.53/.41) | | |
| 28a | 2-Spd Xmsn Drawbar Pull @ Maximum RL/NL | lb (kg) 9514/5674 (4315/2574) | 10000/5674 (4536/2574) | 10500/5674 (4763/2574) | 9452/5952 (4536/2700) | 10000/5952 (4536/2700) | 11500/5952 (5216/2700) |
| 28b | 2-Spd Xmsn Drawbar Pull @ 1 mph RL/NL | lb (kg) 7773/5674 (3526/2574) | 8557/5674 (3881/2574) | 10500/5674 (4763/2574) | 7713/5952 (3498/2700) | 8474/5952 (3844/2700) | 10500/5952 (4763/2700) |
| 28c | 2-Spd Xmsn Drawbar Pull @ 3 mph RL/NL | lb (kg) 4940/5674 (2241/2574) | 4979/5674 (2258/2574) | 7334/5674 (3327/2574) | 4874/5952 (2211/2700) | 4914/5952 (2229/2700) | 7281/5952 (3303/2700) |
| 29a | 2-Spd Xmsn Minimum Gradeability RL/NL | % 30/17 | 32/17 | | 37/17 | 29/17 | |
| 29b | 2-Spd Xmsn Gradeability @ 1 mph RL/NL | % 24/17 | 27/17 | | 33/17 | 22/17 | |
| 29c | 2-Spd Xmsn Gradeability @ 3 mph RL/NL | % 15/17 | 23/17 | | 14/17 | | 20/17 |
| 28a | 3-Spd Xmsn Drawbar Pull @ Maximum RL/NL | lb (kg) 10000/5674 (4536/2574) | 10000/5674 (4536/2574) | 11500/5674 (5216/2574) | 10000/5952 (4536/2700) | 10000/5952 (4536/2700) | 11500/5952 (5216/2700) |
| 28b | 3-Spd Xmsn Drawbar Pull @ 1 mph RL/NL | lb (kg) 10000/5674 (4536/2574) | 10000/5674 (4536/2574) | 11500/5674 (5216/2574) | 10000/5952 (4536/2700) | 10000/5952 (4536/2700) | 11500/5952 (5216/2700) |
| 28c | 3-Spd Xmsn Drawbar Pull @ 3 mph RL/NL | lb (kg) 6309/5674 (2862/2574) | 5268/5674 (2389/2574) | 7366/5674 (3341/2574) | 6248/5952 (2834/2700) | 5221/5952 (2368/2700) | 7307/5952 (3315/2700) |
| 29a | 3-Spd Xmsn Minimum Gradeability RL/NL | % 32/17 | 37/17 | | 29/17 | | 33/17 |
| 29b | 3-Spd Xmsn Gradeability @ 1 mph RL/NL | % 32/17 | 37/17 | | 29/17 | | 33/17 |
| 29c | 3-Spd Xmsn Gradeability @ 3 mph RL/NL | % 19/17 | 16/17 | | 17/17 | 15/17 | |
| 30a | Weight, Standard Truck NL | lb (kg) 19660 (8918) | 19770 (8968) | | 20792 (9431) | 20902 (9481) | |
| 30b | Weight, Standard Truck RL | lb (kg) 33161 (15042) | 33271 (15092) | | 36293 (16462) | 36403 (16512) | |
| 31a | Axle Loading, Static Front/Rear NL | lb (kg) 9457/10203 (4290/4628) | 9512/10258 (4315/4653) | | 9160/11632 (4155/5276) | 9215/11687 (4180/5301) | |
| 31b | Axle Loading, Static Front/Rear RL | lb (kg) 30268/2893 (13729/1312) | 30323/2948 (13754/1337) | | 33051/3239 (14992/1469) | 33106/3294 (15017/1494) | |
| 32 | Tire Size, Front / Rear | 8.25 X 15 14PR / 8.25 X 15 14PR | | | 8.25 X 15 14PR / 8.25 X 15 14PR | | |
| 34 | Wheelbase | 88.0 (2235) | | | 88.0 (2235) | | |
| 35 | Ground Clearance Under Mast, RL | 5.7 (146) | | | 5.7 (146) | | |
| 36 | Ground Clearance, Center of Wheelbase | 10.0 (253) | | | 10.0 (253) | | |
| 37 | Service Brake - Method of Control/Operation | Foot / Hydraulic | | | Foot / Hydraulic | | |
| 38 | Park Brake - Method of Control/Operation | Hand / Mechanical | | | Hand / Mechanical | | |
| 39 | Battery Type | Maintenance Free | | | Maintenance Free | | |
| 40 | Volts / Cold Cranking Amps | v / cca 12V/475 | 12V/900 x 2 | | 12V/475 | 12V/900 x 2 | |
| 41 | Engine Manufacturer | PSI 4.3L | | | Kubota 3.8L Turbo Diesel | | |
| 42 | Engine Power @ Governed Speed | hp (kw) 96 (72) @ 2400 RPM | 74 (55) @ 2200 RPM | 105 (79) @ 2200 RPM | 96 (72) @ 2400 RPM | 74 (55) @ 2200 RPM | 105 (79) @ 2200 RPM |
| 43 | Torque @ Rated RPM | ft lbs. (Nm) 210 (285) @ 2400 RPM | 227 (309) @ 1400RPM | 275 (373) @ 1600RPM | 210 (285) @ 2400 RPM | 227 (309) @ 1400RPM | 275 (373) @ 1600RPM |
| 44 | Number of Cylinders / Displacement | 6/4302 (263) | | | 4/3769 (230) | | |
| 45 | Transmission Type, Standard | Powershift | | | Powershift | | |
| 46a | Standard Speeds, Forward/Reverse | 2/2 | | | 2/2 | | |
| 46b | Optional Speeds, Forward/Reverse | 3/2 | | | 3/2 | | |
| 47 | Hydraulic Tank Capacity (Drain and Refill) | 18.9 (71.7) | | | 18.9 (71.7) | | |
| 48 | Fuel Tank Capacity (Diesel Powered Units Only) | 19.7 (74.8) | | | 19.7 (74.8) | | |
| 49 | Auxiliary Hydraulic Pressure Relief for Attachments | PSI (Mpa) 2250 (155) | | | 2250 (155) | | |

CERTIFICATION: These Hyster lift trucks meet design specifications of Part II ANSI B56.1-1969, as required by OSHA Section 1910.178(a)(2) and also comply with Part III ANSI B56.1-revision in effect at time of manufacture.

Certification of compliance with the applicable ANSI standards appears on the lift truck.

† **NOTE:** Performance specifications / ratings are for truck equipped as described under Standard Equipment in this Technical Guide. Performance specifications are affected by the condition of the vehicle and how it is equipped, as well as by the nature and condition of the operating area. Specifications are subject to change and the proposed application should be discussed with your authorized Hyster Company Dealer.

†† Limited by traction. For further information on this dimension, please contact your local Hyster dealer.

STANDARD EQUIPMENT

- PSI 4.3L, V-6 emissions compliant engine
- Electronic powershift transmission
 - Hydraulic inching
 - Electronic shift control
 - 2 speeds forward, 2 speeds reverse
- Premium oil-cooled wet disc brakes
- MONOTROL® pedal
- 2-Stage limited free-lift (LFL) VISTA™ mast with maximum fork height of 133" (2400 mm)
- 48.0" (1219 mm) wide hook-type carriage with 48.0" (1219) tall load backrest extension
- 48.0" (1219 mm) long forks
- 6 degrees forward and 10 degrees backward mast tilt
- 3-function hydraulic control valve
- Integrated dashboard display includes:
 - LCD display:
 - Fuel level (diesel only)
 - Hour meter
 - Coolant temperature
 - Clock
 - Messages
 - Service indicator lights:
 - Alternator
 - Transmission oil temperature
 - Engine oil pressure
 - Brake fluid level
 - Fasten seat belt
 - Low fuel level
 - Engine malfunction
 - System malfunction
 - Park brake
 - Coolant temperature
 - Forward, reverse and neutral direction indicators
- Hydrostatic power steering
- Non-suspension vinyl seat
- No-cinch seat belt
- Electronic horn
- Adjustable steer column
- Rubber floor mat
- High air intake
- Integral tie downs
- Operator restraint system
- Combi-cooler radiator
- Single pedal inch brake
- Cowl-mounted hydraulic control levers
- Swing out LPG tank bracket
- Pressure sensing low LPG fuel sensor
- 100" (2531 mm) tall overhead guard
- 12 months / 2,000 hours manufacturer's warranty
- 36 months / 6,000 hours manufacturer's powertrain warranty
- Operator's manual
- UL Classification LPG

OPTIONAL EQUIPMENT

- Kubota 3.8L EPA Certified Tier 4 Final high output turbo diesel engine
- Kubota 3.8L DOC EPA Certified Tier 4 Final turbo diesel engine
- DuraMatch™ transmission
 - Electronic inching
 - Electronic shift control
 - Auto deceleration system
 - Controlled power reversal
 - Controlled roll back on ramps
 - 3 speeds forward, 2 speeds reverse
- LED lights (brake/tail/back-up)
- Powertrain protection system
- Premium monitoring
- High air intake with precleaner
- Accumulator
- Keyless start (with auxiliary key switch)
- Dual LPG tank bracket
- Return to set tilt
- TouchPoint hydraulic mini-levers with fully adjustable armrest
- Rear drive handle with horn button
- Full suspension seat - vinyl or cloth
- Swivel full-suspension seat - vinyl or cloth
- High-visibility non-cinch seat belt with or without interlock
- Impact monitor with immediate or delayed shutdown
- Load weight display
- Operator pre-shift checklist
- Dual-inch brake pedals
- Operator password protection
- Audible reverse activated 82-102 dB(A) self-adjusting alarm
- Visible amber LED strobe light - continuously activated, overhead guard mounted
- Parts publications - printed or CD, serial number specific
- UL Classification D, LPS, DS
- Various light packages available with halogen or high intensity LED:
 - Two front and one rear work lights
 - Two front, one rear work light and two brake/tail/back-up lights
- Cab includes the following:
 - Front and rear wiper
 - Full light package
 - Integral heater
 - Defogger
 - Removable doors
 - Operator dome light
 - Fan
 - Optional air conditioning
- Side view mirrors



Hyster Company
P.O. Box 7006
Greenville, North Carolina
27835-7006
Part No. H135-155FT/ TG
3/2017 Litho in U.S.A.

Visit us online at www.hyster.com or call us at **1-800-HYSTER-1**.

Hyster, , and STRONG PARTNERS. TOUGH TRUCKS. and MONOTROL are registered trademarks in the United States and certain other jurisdictions. Hyster products are subject to change without notice.

Trucks may be shown with optional equipment. © 2017 Hyster Company. All rights reserved.