



An ISO 9001:2000 Certified Company

Autocar MY 2018 4x2 DOT/EPA Compliant Terminal Tractor Standard Specifications

Engine and Equipment	Standard	Optional
Engine model	Cummins '13/17 ISB diesel - 200 HP @ 2600 RPM 520 ft-lb torque @ 1600 RPM	Cummins '13/17 ISB Diesel - 260HP @ 2600RPM/660 LB-FT @ 1600RPM Cummins ISL-G (CNG/LNG) - 260HP @2200RPM/660 LB-FT@1600RPM
Exhaust	Horizontal DPF w/ vertical SCR; 5 gallon DEF tank, right side mounted	10 gallon DEF tank, Vertical DPF/SCR (2017 ISB)
Air cleaner	Donaldson 11 inch single stage	11" 2 stage/Donaldson inline precleaner/Donaldson topspin precleaner/exhaust turn-out
Radiator	1000 sq in copper brass	
Fan & drive	Viscous Fan Drive	
Coolant hoses/piping	Silicone hoses with steel tubing	
Coolant	Extended life coolant	
Engine Equipment	Fleetguard FS 1003 F/W Separator w/ probe & dash light	Fleetguard FS 1003 with heat/Davco 382 with heat Engine block heater (750/1000W)/Oil pan heater/engine oil sample port Arctic Fox in-tank fuel heater w/ thermostat

Transmission and Equipment

Transmission model	Allison 3000 RDS	(Allison 3500 RDS)
Transmission gearing	4-speed	(3-speed or 5-speed)
Transmission controls	Allison push button	(Allison t-handle)
Transmission cooler	Oil to water type	
Transmission lubricant	TranSynd™ synthetic	
Driveshaft	Dana Spicer® 1710 half-round	

Front Axle and Equipment

Axle model	Meritor MFS Widetrack (14,700lb rated)	Dana Spicer® E-1322-W (13,200 lb rated)
Front suspension	Flat leaf (14,500 lb rated)	
Shock absorbers	Double acting - heavy duty	
Power steering	Gearbox, integral steering w/ mechanical backup	
Power steering reservoir	Integral w/ hydraulic tank	
ABS	Bendix 4S4M w/o traction control	(required for vehicle speeds over 33 MPH)
Brakes	16.5 x 5 s-cam	
Brake drums	Cast iron	
Slack adjusters	Meritor automatic slack adjusters	Haldex slacks
Front hubs	Iron hub piloted	

Rear Axle and Equipment

Axle model	Meritor S24-160 (single reduction)	(Meritor RS23-186, RS30-380) (Dana Spicer® S23-170, S23-190, S30-190 & S30-590) (Sisu 30 S Planetary axle)
Rear axle ratio	7.17:1	(ratio based on selected axle & performance)
Rear suspension	Solid	Rear spring suspension w/ aeon cushions
ABS	Bendix 4S4M w/o traction control	(required for vehicle speeds over 33 MPH)
Brakes	16.5 x 7 s-cam	
Brake drums	Cast iron	
Slack adjusters	Meritor automatic slack adjusters	Haldex slacks
Rear hubs	Iron hub piloted	
Gear lubricant	Synthetic	

Chassis and Equipment

Wheelbase	116 inch	122", 128"
Frame	2.0 million RBM, 50,000 KSI steel, 'C'-reinforced	
Frame fasteners	Huck bolts where possible	
Bumper	Steel reinforced bumper	Heavy duty reinforced bumper
Tow device(s)	Front & rear tow eyes	
Mud flaps	Rear of drive tires	

Pneumatic System (Rapid Fill)

Air compressor	Wabco 18.7 CFM	
Air system drain valve	Manual petcocks all tanks	Pull cords on all tanks, 1/4 turn valve tank drains
Air lines	Nylon, color coded	
Brake system	121 air brake system, front/rear system protection	

Fuel System

Fuel tank	50 gallon steel rectangular w/ deep step, left side mounted	50 gallon step tank, 40 gal round tank (18" dia)
Fuel filter	Cummins	
Fuel lines	SAE J844 nylon	

5th Wheel and Hydraulic System

5th wheel	SAF/Holland 70,000 lb semi-oscillating 16 inch lift bearings	(SAF/Holland 100,000 lb, Jost, Fontaine options)
Hydraulic lift cylinders	(2) 5 inch 50,000 lb capacity, upper & lower spherical bushings	(limited lift height cylinders)
Hydraulic tank	15 gallon steel tank w/ sight glass	
Pump	Engine mounted	Chelsea PTO 280-5RK

Trailer Equipment

Air connections	15' straight rubber trailer hoses w/spring hanger	12 ft color coded coiled w/ glad-hands
7-way electric cable receptacle	7-way electric cable 12 FT	12 ft coiled detachable

Tires and Wheels

Front tires	11R22.5 Doublecoin	Low-Pro (295/280/275)/Goodyear, Michelin, Continental
Front wheels	Steel 22.5 x 8.25 hub piloted, 285mm BC	22.5x8.25" Steel 2 HH wheel, customer supplied wheels/tires
Rear tires	11R22.5 Doublecoin	Low-Pro (295/280/275)/Goodyear, Michelin, Continental
Rear wheels	Steel 22.5 x 8.25 hub piloted, 285mm BC	22.5x8.25" Steel 2 HH wheel, customer supplied wheels/tires V2B flow through valve caps

Electrical System

Electrical System	12V, negative ground	
Alternator	Delco Remy 22SI 130AMP	Delco 160 AMP, 28SI w/ Remote Sense pad mount Mitsubishi 12V 160 AMP pad mount
Starter	Denso 12V	
Batteries	(2) group 31 950 CCA (min)/1900 CCA total	2000CCA, 3000CCA, AGM batteries 1800CC, 2300 CCA
Circuit protection	Automatic circuit breakers	
Windshield wipers	Single electric (pantograph) intermittent w/washer	(single radial arm overhead, horizontal park)
Backup alarm	Non-motion detecting	(motion detecting, CA compliant)
Horn	Single	(air horn - roof or under-cab mounted)

Lighting

Headlamps	Low/high halogen	LED Headlights, Spot-style headlights, direct wired
Backup light, stop & turn signals	LED stop & turn, incandescent backup, shock resistant mount	LED spot lights, alternate positioning
BOC 5th wheel light	Incandescent, shock resistant mount	
Marker and side turn signals	LED	

Cab and Equipment

Cab construction	• Electrocoated (e-coated) steel, full cab immersion • (Rust Prevention Coating)	
Cab dimensions (outside)	Raised roof, 52" wide x 71" deep (w/o rear door) x 78" high (deck to roof)	
Cab doors	Left side hinged door w/ manual crank window, aluminum sliding rear door	
Rear door opening (useable)	24" wide x 72" high	
Cab floor	Sweep out floor w/ durable mat	
Cab dash	Steel wrap around	
Overhead console	Steel	
Cab mounting	4 point, rear dual (2) air suspensions	3-point spring
Cab tilt	Electric over hydraulic	
Glass	Tinted, laminated windshield	
Mirrors	Dual SST west coast mirrors	(heated primary, motorized primary, convex)
Cab climate control system	44,000 BTU fresh air heater	(air conditioning)
Steering column	Fixed	Tilt/telescopic
Steering wheel	18 inch 2-spoke	
Seat	Air suspension, mid-back without fore/aft isolation	(air suspension, mid-back with fore/aft isolation)
Seat covering	Black Cordura Plus® cloth fabric	Vinyl seat cover
Seat belt	3-point orange	
Dome light	Switch on dash	
Power ports	(2) 12V	
Air horns	Mounted under cab	Mounted R/S top of cab
Translucent sun visor	Single	
Conspicuity tape		

Operators Controls

Park brake - push/pull
Headlamps
Turn signal - column mounted
Brake pedal (dual pedal optional)
Accelerator pedal
5th wheel height control
5th wheel lock
Transmission gear selector - Push button

Cab Instrumentation

Speedometer
Engine oil pressure
Coolant temperature
Transmission oil temperature
Fuel level/ DEF level
Primary (A) air pressure
Secondary (B) air pressure
Hour meter
Voltmeter - optional
Tachometer - optional

Cab Warning Devices

Park brake
High beam
Turn signal
Low fuel
Low air
Seat belt
DPF
HEST
Air restriction indicator
Filter with water in fuel indicator
Fifth Wheel height indicator/lock indicator - optional

Paint

Cab	White	(customer specific colors)
Chassis	Black	(customer specific colors)
Bumper	Black	(customer specific colors)
Wheels	White powder coat	(customer specific colors)

Optional Equipment

Air Dryer (ADIP, AD-9, Wabco)	Glad-hand and 7-way cable storage	Cab fan
Fuel/water separator w/ heater	Battery disconnect switch	AM/FM radio/CD w/ aux input, speakers & antenna
Engine block heater	Air restriction indicator w/ dash light	5# ABC fire extinguisher
Oil pan heater	Amber beacon light	Triangle kit
Beavertail/frame extension/kingpin guides	Spot/work/flood lights	Additional instrumentation
Front axle mudflaps	Rear door laminated glass	Lever start, no key/pushbutton start
Rear axle mudflap (front)	Training seat	Double blink strobe light, other strobe/beacon options
Rear flexible fenders	Auto lube system (Interlube)	Trailer hand brake
Fender skirt/splash protector	Trailer stops/full cab guard	Two stage air cleaner
Glad hand buckets	Dock bumpers (cab)	Trailer Rapid fill system
Additional engine tunnel insulation	Additional decking, side cab catwalk	Pneumatic 5th wheel lockout
360 degree swivel trailer light	Safety yellow decking	Cab document storage
Premium seating options (swivel, heated)	Diamond plate cab floor	Dollymaster, pintle hook options
Rear diff lock	RH deck access steps	

Vehicle Ratings

Vehicle tare weight, front	
Vehicle tare weight, rear	
GAWF	13,200 lbs
GAWR	23,000 lbs
GCW	80,000 lbs

Performance

Basic Warranties (Industry Best)

Autocar terminal tractor	1 year or 3,000 hours whichever occurs first, parts & labor	
Frame	7 years or 20,000 hours whichever occurs first	
Cummins engine	ISB - 3 years parts & labor (2,000 hours)	
Allison transmission	3 years parts & labor	5 year optional
Dana axles	3 years parts & labor	
Meritor Axles	(24-160 only) 6 months, parts only	2 years parts & labor

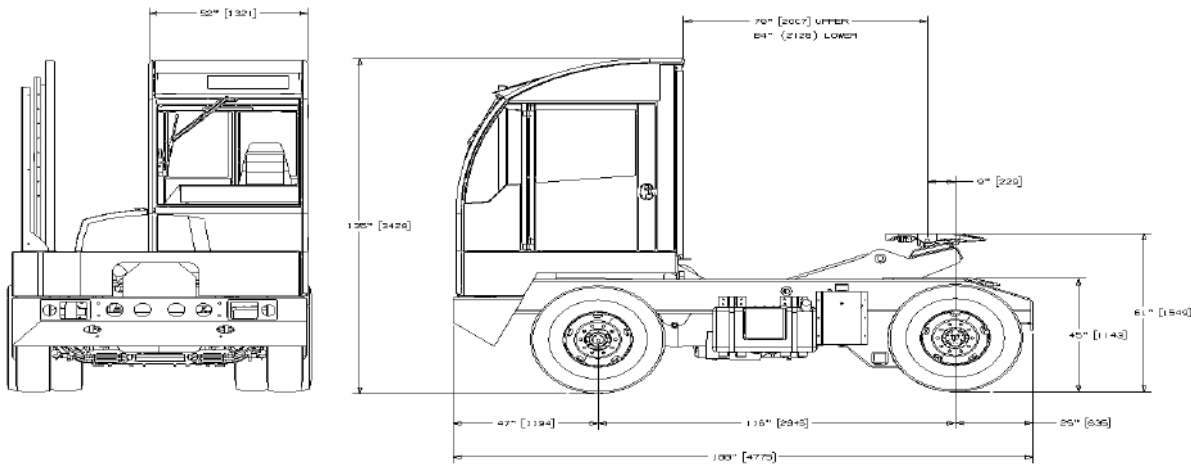

Autocar Industries, LLC • 551 South Washington Street • Hagerstown, IN 47346
 Toll Free: 877-973-3486 • Fax: 765-489-5230 • www.autocartruck.com