



**STRONG PARTNERS.
TOUGH TRUCKS.™**



H360-36/48HD SERIES TECHNICAL GUIDE

WWW.HYSTER.COM

> H360-36/48HD DIMENSIONS

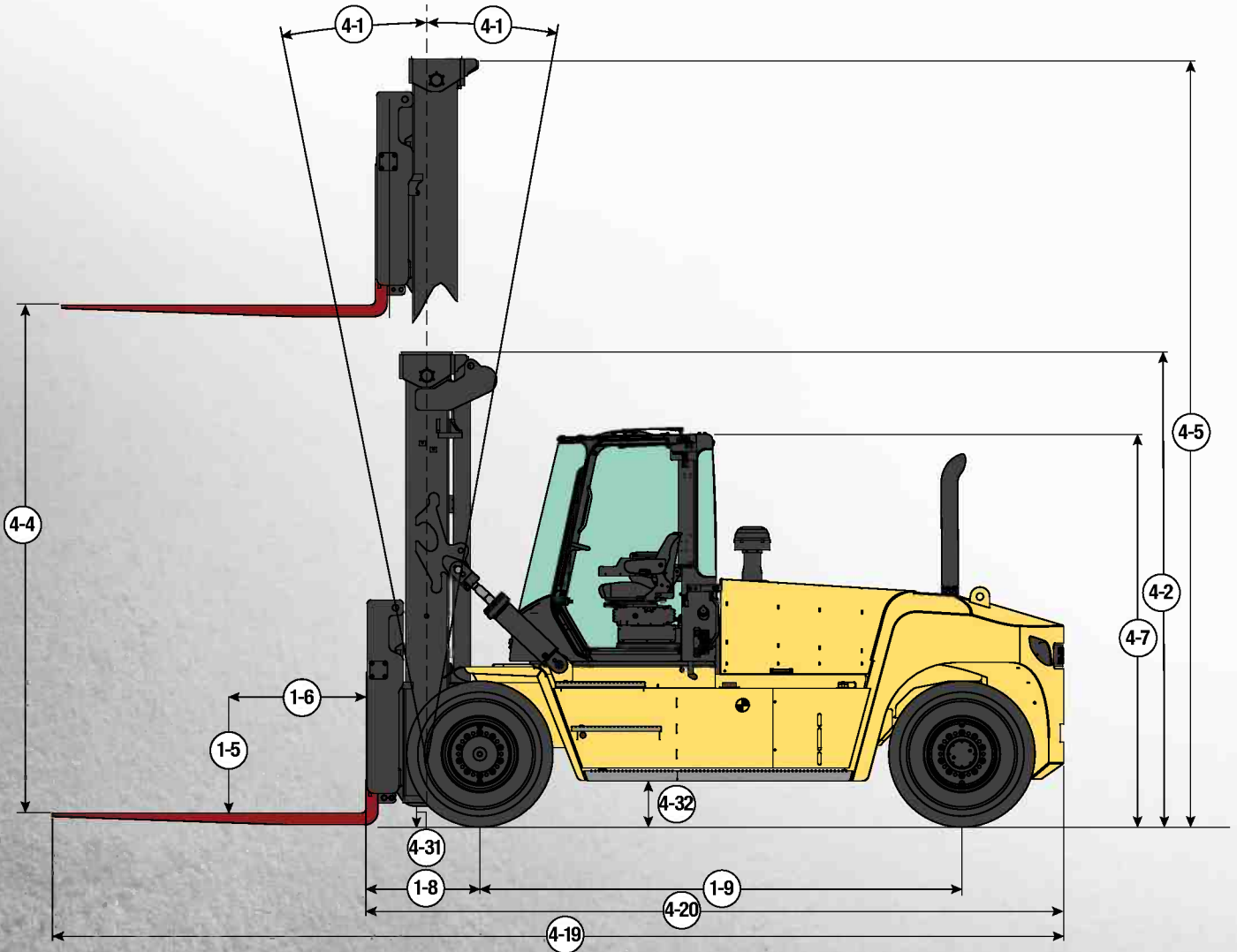
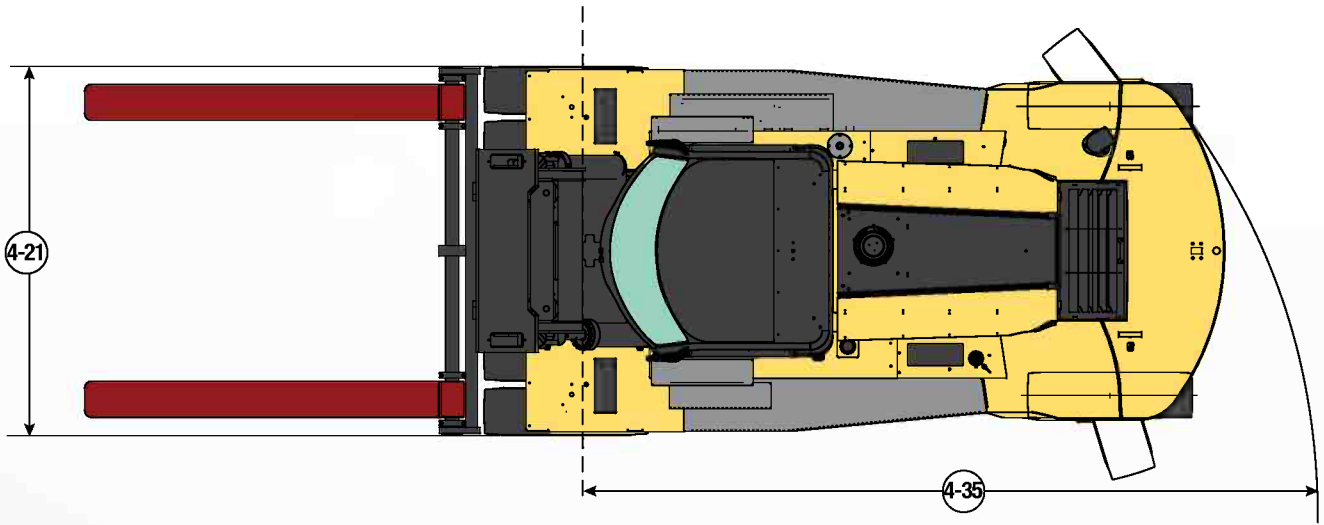

Circled dimensions correspond to the line numbers on the tabulated chart inside the Technical Guide. Dimensions are in inches (millimeters).

> H360-36/48HD SPECIFICATIONS

| | Description | Units | | English | Metric | English | Metric | |
|--------------------|--|--|--------------|--|--|---------------|-----------|--|
| | | | | | | | | |
| GENERAL | 1-1 | Manufacturer | | HYSTER | HYSTER | HYSTER | HYSTER | |
| | 1-2 | Model designation | | H360-36HD | H360-36HD | H360-48HD | H360-48HD | |
| | 1-5 | Rated load capacity | | lbs | kg | 36,000 | 16,329 | |
| | 1-6 | Load center | | in | mm | 36 | 914 | |
| | 1-8 | Load distance | | in | mm | 34.9 | 887 | |
| | 1-9 | Wheelbase | | in | mm | 148 | 3,750 | |
| WEIGHTS | 2-1 | Total truck weight without load | | lbs | kg | 47,186 | 21,403 | |
| | 2-2a | Axle loading with load | front | lbs | kg | 77,110 | 34,977 | |
| | 2-2b | | rear | lbs | kg | 6,076 | 2,756 | |
| | 2-3a | Axle loading without load | front | lbs | kg | 23,817 | 10,803 | |
| | 2-3b | | rear | lbs | kg | 23,369 | 10,600 | |
| WHEELS | 3-1 | Tire type | | Pneumatic | | Pneumatic | | |
| | 3-2 | Tire size | front | 12.00x20 Bias | | 12.00x20 Bias | | |
| | 3-3 | | rear | 12.00x20 Bias | | 12.00x20 Bias | | |
| DIMENSIONS | 4-1 | Mast tilt, forward / back | | degrees | | 15 / 10 | | |
| | 4-2 | Height of mast lowered | | in | mm | 145 | 3,680 | |
| | 4-3 | Freelift (Top of Fork) | | in | mm | 0 | 0 | |
| | 4-4 | Lift height (Top of Fork) | | in | mm | 156 | 3,984 | |
| | 4-5 | Height of mast extended | | in | mm | 222 | 5,622 | |
| | 4-7 | Height to top of operator compartment | | in | mm | 120 | 3,054 | |
| | 4-19 | Overall length | | in | mm | 310 | 7,878 | |
| | 4-20 | Length to load face | | in | mm | 214 | 5,438 | |
| | 4-21 | Overall width over drive tires | | in | mm | 100 | 2,542 | |
| | 4-22a | Fork | thickness | in | mm | 3.9 | 100 | |
| | 4-22b | | width | in | mm | 7.9 | 200 | |
| | 4-22c | | length | in | mm | 96 | 2,440 | |
| | 4-24 | Carriage width | | in | mm | 100 | 2,540 | |
| | 4-25a | Fork spread, min (in-in) | | in | mm | 9 | 235 | |
| | 4-25b | Fork spread, max (out-out) | | in | mm | 94 | 2375 | |
| | 4-31 | Ground clearance, under mast with load | | in | mm | 7 | 187 | |
| | 4-32 | Ground clearance, center of wheelbase | | in | mm | 14 | 368 | |
| | 4-33 | Minimum aisle width (add load length + clearance) | | in | mm | 236 | 5,984 | |
| | 4-35 | Outside turning radius | | in | mm | 205 | 5,199 | |
| MISC. | 8-7 | Hydraulic tank capacity | | gal | l | 42 | 160 | |
| | 8-8 | Fuel tank capacity | | gal | l | 54 | 206 | |
| | 10-4 | DEF tank capacity | | gal | l | 5.0 | 19.0 | |
| PERFORMANCE | | | | WITH TIER 4 FINAL CUMMINS QSB 6.7L ENGINE | | | | |
| PERFORMANCE | 5-1a | Travel speed | with load | mph | km/h | 17 | 27 | |
| | 5-1b | | without load | mph | km/h | 18 | 29 | |
| | 5-2a | Lifting speed | with load | ft/min | m/s | 77 | 0.39 | |
| | 5-2b | | without load | ft/min | m/s | 87 | 0.44 | |
| | 5-3a | Lowering speed | with load | ft/min | m/s | 106 | 0.54 | |
| | 5-3b | | without load | ft/min | m/s | 89 | 0.45 | |
| | 5-6 | Drawbar pull – Max | | lbs | kN | 26,700 | 119 | |
| | 5-7 | Gradeability – no load / rated load – 1 mph (1.6 km/h) | | | | % | 35/31 | |
| | PERFORMANCE | | | | WITH TIER 3 CUMMINS QSB 6.7L ENGINE | | | |
| | 5-1a | Travel speed | with load | mph | km/h | 17 | 27 | |
| | 5-1b | | without load | mph | km/h | 18 | 29 | |
| | 5-2a | Lifting speed | with load | ft/min | m/s | 67 | 0.34 | |
| | 5-2b | | without load | ft/min | m/s | 87 | 0.44 | |
| | 5-3a | Lowering speed | with load | ft/min | m/s | 106 | 0.54 | |
| 5-3b | | without load | ft/min | m/s | 89 | 0.45 | | |
| 5-6 | Drawbar pull – Max | | lbs | kN | 24,500 | 113 | | |
| 5-7 | Gradeability – no load / rated load – 1 mph (1.6 km/h) | | | | % | 35/27 | | |

CERTIFICATION: These Hyster® lift trucks meet design specifications of Part II ANSI B56.1-1969, as required by OSHA Section 1910.178(a)(2) and also comply with Part III ANSI B56.1-revision in effect at time of manufacture. Certification of compliance with the applicable ANSI standards appears on the lift truck. Performance specifications are for a truck equipped as described under Standard Equipment on this Technical Guide. Performance specifications are affected by the condition of the vehicle and how it is equipped, as well as by the nature, condition of the operating area, proper service and maintenance of the vehicle. If these specifications are critical, the proposed application should be discussed with your dealer.

H360-36/48HD SPECIFICATIONS



| H360-36/48HD MAST DIMENSIONS | | | | | | | |
|-------------------------------------|------|-------------------------|------|-------------------------------|----|-----------------------------|------|
| 4.4 Lift height (Top of Fork) | | 4.2 Mast Lowered Ht. | | 4.3 Freelift (Top of Fork) | | 4.5 Overall Extended Ht. | |
| in | mm | in | mm | in | mm | in | mm |
| 2-STAGE NO FREE-LIFT (NO FL) | | | | | | | |
| 156 | 3984 | 145 | 3680 | 0 | 0 | 222 | 5622 |
| 180 | 4594 | 157 | 3984 | 0 | 0 | 246 | 6232 |
| 212 | 5406 | 173 | 4390 | 0 | 0 | 278 | 7044 |
| 244 | 6219 | 189 | 4797 | 0 | 0 | 310 | 7858 |

| POWERTRAINS | | UNITS | TIER 4 FINAL | | TIER 3 | |
|-------------|------------------------------------|-----------|------------------------------------|------|-------------------------|------|
| 1-3 | Power type | | Diesel | | Diesel | |
| 7-1 | Engine Manufacturer / model | | Cummins QSB 6.7L | | Cummins QSB 6.7L | |
| 7-1a | EPA Tier Compliance | | Tier 4 Final | | Tier 3 | |
| 7-2a | Engine power output - Rated | | 164 | 122 | 155 | 116 |
| 7-2b | Engine power output - Peak | hp kW | 168 | 125 | 155 | 116 |
| 7-3 | Governed speed | rpm | 2,300 | | 2,300 | |
| 7-4 | Number of cylinders / displacement | # / l | 6/6.7L | | 6/6.7L | |
| 7-5 | Engine torque - Max | lb-ft N-m | 540 | 732 | 443 | 600 |
| 7-5a | Turbocharger | Type | Variable Geometry, Water Cooled | | Wastegate | |
| 7-8 | Alternator output | Amps | 120 | | 120 | |
| 8-0 | Transmission Manufacturer / model | | ZF WG-161 | | ZF WG-161 | |
| 8-1 | Transmission type & speeds | | Powershift 3F x 3R | | Powershift 3F x 3R | |
| 7-10 | Battery voltage, rated capacity | V / CCA | 2 x 12 / 900 | | 2 x 12 / 900 | |
| 7-10a | Drive Axle Manufacturer / model | | Kessler D81 | | Kessler D81 | |
| 5-10 | Service brake | | Oil immersed (wet) disc | | Oil immersed (wet) disc | |
| 5-11 | Park brake | | Spring apply, dry disc | | Spring apply, dry disc | |
| 10-1 | Working pressure for attachments | psi Mpa | 2,828 | 19.5 | 2,828 | 19.5 |
| 10-2 | Oil flow for attachments | gpm l/m | 26.4 | 102 | 26.4 | 102 |

RATED CAPACITIES

NOTE: Higher capacity rated versions up to 40,000 lbs. at shorter load centers are available upon request on a custom basis. Please contact Hyster Company for details & SPED Quote.

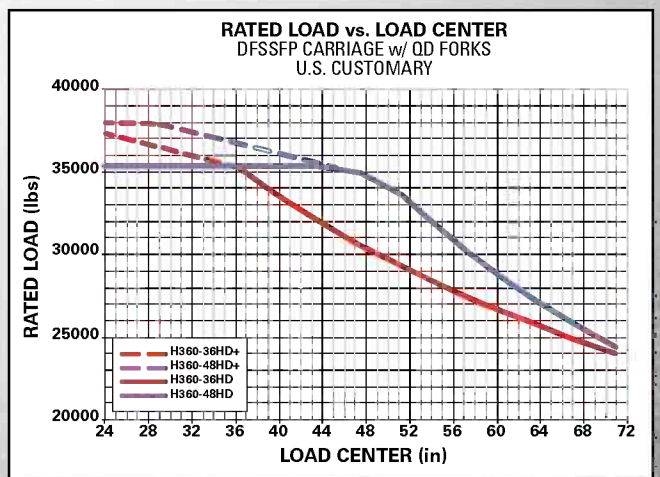
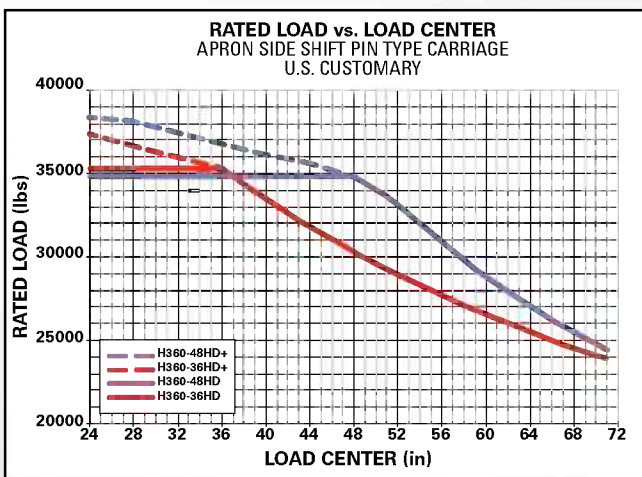
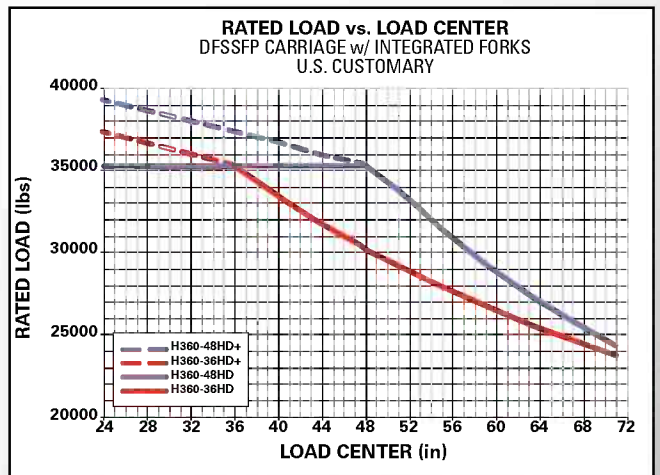
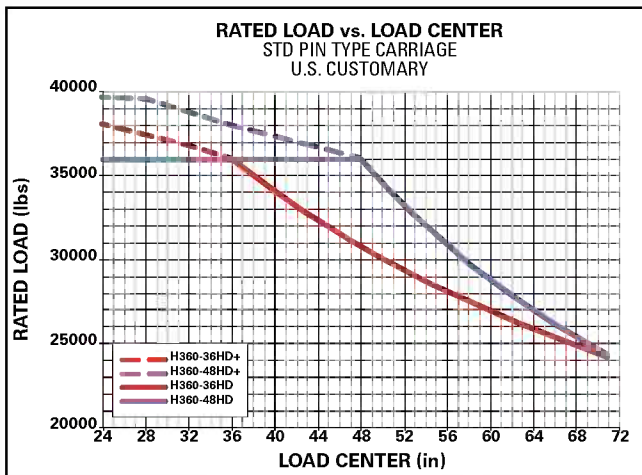

Model H360-36HD: 36,000 lbs. at 36" (16,329 kg at 914 mm) load center
 Model H360-48HD: 36,000 lbs. at 48" (16,329 kg at 1220 mm) load center

Conversion Factor: 1.0" = 25.4 mm
 1 lb = 0.45 kg

Rated capacities are for trucks equipped with:

- 2-Stage mast to 156" (3984 mm) maximum fork height
- 100" (2540 mm) carriage width
- 96" (2440 mm) long forks

Contact your dealer for other capacity information.

> STANDARD FEATURES AND OPTIONS

MASTS

Masts with nested channels provide maximum visibility of the attachment and load. Mast channels, rollers, stub shafts and chain anchors are reinforced to provide good torsional rigidity. Oversized stub shafts are inset and double welded for good impact resistance. Chains designed on outside of mast to enhance visibility window.

CARRIAGES

Pin-type; integral pin-type fork positioner with simultaneous or individual fork control; pin-type integral sideshift; integral pin-type dual function sideshift fork positioner; apron style sideshift fork positioner with simultaneous or individual fork control.

Overall width is 100" (2540 mm) for the H360-36/48HD

Minimum inside-to-inside fork spacing - model and attachment dependent is 9" (235 mm)

Maximum outside-to-outside fork spacing - model and attachment dependent is 94" (2375 mm)

FORKS

Three kinds of forks are offered in two sizes.

i. PIN TYPE - STANDARD PROFILE available in:

- 96" long x 3.9" x 7.9" (2440mm x 100mm x 200mm)
- 96" long x 3.5" x 9.8" (2440mm x 90mm x 250mm)

ii. INTEGRAL PIN TYPE (FOR USE WITH DFSSFP) available in:

- 96" long x 3.9" x 7.9" (2440mm x 100mm x 200mm)
- 96" long x 3.5" x 9.8" (2440mm x 90mm x 250mm)

iii. QD HOOK TYPE (FOR USE WITH DFSSFP - QUICK DISCONNECT) available in:

- 96" long x 3.9" x 7.9" (2440mm x 100mm x 200mm)
- 96" long x 3.5" x 9.8" (2440mm x 90mm x 250mm)

STANDARD ENGINE - TIER 4 FINAL

QSB 6.7L 6 cylinder diesel engine delivers 164 hp (peak 168 hp) and 540 lb-ft of maximum torque. EPA Tier 4 Final compliant engine features cooled exhaust gas recirculation (EGR) technology with selective catalytic reduction (SCR); water-cooled variable geometry turbocharger with an integrated Diesel Exhaust Fluid (DEF) delivery system. Innovative selectable ECO performance modes offer excellent fuel economy and maximum productivity. Also includes:

- 120 amp alternator
- Viscous, on-demand cooling fan which saves fuel and reduces noise
- Low mount exhaust with diesel oxidation catalyst (DOC) and a diluter to reduce exhaust temperatures
- Requires ultra-low sulfur diesel fuel and low-ash oil
- Heavy duty spinner type Sy-Klone pre-cleaner center stacked for ease of service and enhanced visibility

TRANSMISSION

- ZFWG-161 three-speed, fully reversing powershift transmission produces smooth shifting, precise inching and fast acceleration
- 3 forward and 3 reverse gears
- Smooth fully automatic gear shift control
- Powershift transmission with proportional valves
- Inching electronically controlled
- Cushioned clutch lock-up provides smooth shifting and dampens drive line shock loads
- Simple push button calibration
- Transmission lock-out preventing high speed directional changes
- Transmission and engine powertrain protection for excessive engine coolant temperature, low engine oil pressure, and excessive engine inlet air temperatures

ELECTRICAL SYSTEM

- Sealed Deutsch connectors
- CANbus system for easy diagnostics of engine, transmission and hydraulics

HYDRAULIC SYSTEM

Hyster on-demand load sensing hydraulic system introduces an efficient way to meet truck's hydraulic load demands:

- Based on Variable Displacement Pump (VDP) technology
- Pump is only pumping when oil is needed
- Less heat is produced - oil and filters last longer. Hoses, seals, and components also wear less and last longer
- Engine runs quieter and at lower speeds, extending life of major components
- Leak free O-Ring Face Seal (ORFS) fittings standard throughout the truck
- Capable of more oil displacement even at low engine speeds

STEERING SYSTEM

- Designed for high loads and long life, the one piece axle frame carries the axle loads and provides mounting for the spindles and cylinder
- Axle spindles are supported by oil bathed wheel bearings and sealed to prevent contamination entry or loss of oil. This ensures that oil bearings are always lubricated and enhances overall durability of the axle spindles
- No steering linkage adjustments are required. Lubricating fittings on tie rod pins are the only regular maintenance points
- Load sensed steering provides low steering effort and good performance at all engine speeds
- Fully adjustable steering angle limiter with mechanical stops - reduces tire scrubbing
- Wheel hubs rotate on large tapered roller bearings
- Non-adjustable tie rod ends provide maximum life

DRIVE AXLE

- Rugged Kessler D81 drive axle features full-floating design

BRAKES

- Oil cooled wet disc brake system
- Designed for load capacities up to 40,000 lbs.
- Axle loads up to 540 kN (121,400 lbs)
- Bolt circle diameter 16.7 inches (425 mm)
- Park brake

OPERATOR AREA

- Ergonomically designed hydraulic controls and high/low range control lever are within easy reach
- Three steps and hand grips provide easy access to operator compartment
- Angled floor plate and pedals are positioned for operator comfort
- Telescopic, tilt steer column
- Supportive mechanical full-suspension seat adjusts 8 inches (200 mm) for operator comfort
- Several air suspension seat options are available
- Steel overhead guard frame provides maximum high-stacking visibility
- Operator Presence System (OPS) with complete hydraulic lock out requires the operator to be in the normal operating position before any travel or movement of the mast, tilt, carriage, and attachment can be initiated and that the travel or movement of the mast, tilt, carriage, and attachment is locked out when the operator leaves the seat for more than 2-3 seconds
- Optional light groups aid visibility in low-lighted areas. Light kits featuring innovative high-performance LED and halogen technology are available
- Optional ComforCabII features: tinted, curved glass; circulation fan; heater & defroster; electric wiper and windshield washer front, rear, top; intermittent front wiper; door retainer; 3 speed fan; 12-volt auxiliary power source; dome light, with many additional options to enhance comfort and productivity

Special attachments, equipment or accessories not listed above may be available through Applications Engineering for specific application requirements.

> STANDARD FEATURES AND OPTIONS

STANDARD EQUIPMENT

- 156" maximum fork height 2-stage mast with 145" overall lowered height
- 100" (2540mm) wide pin type carriage
- 96" long x 3.9" x 7.9" (2440mm x 100mm x 200mm) pin type forks
- Cummins QSB 6.7L Tier 4 Final engine
- Sy-Klone spinner type heavy duty air intake pre-cleaner
- Premium ZF WG161 3 speed autoshift transmission
- Kessler heavy duty planetary drive axle with wet disc brakes
- Powertrain Protection system for engine and transmission; high temperature or low oil pressure
- On-Demand load-sensing hydraulic system featuring Variable Displacement Pump technology (VDP)
- CANbus electrical control system for engine, transmission and hydraulics
- Low mount exhaust
- Low mount air intake
- 12.00 x 20 - 20PR bias high load pneumatic drive and steer tires
- Directional control lever with direction change interlock system
- UL Classification D
- Mast tilt: 15° fwd / 10° back
- Lockable battery disconnect switch
- Open operator compartment with integral overhead guard. Compartment includes: seat-side mini-lever hydraulic control; multifunction display panel; interior wide angle mirrors; handrails for operator entry and exit; telescoping & tilting steering column; floor mat; isolated mounting for low noise and vibration; 24-12V DC converter; full suspension vinyl seat with integrated, adjustable armrest and 2-point high visibility seat belt
- Operator restraint system
- Operator presence system
- Electric air horn (105 dBA)
- Audible backup alarm
- 24V electrical system
- Tilting operator compartment for service access – manual operation
- Light kit #1 - Rear: 2 LED stop, tail and back-up lights
- Steering angle limiter with mechanical stops
- Non-locking fuel cap
- Operator's manual

OPTIONAL EQUIPMENT

- Cummins QSB 6.7L Tier 3 engine*
- Masts - various lift heights available
- Sideshifting carriages and fork positioners
- Various fork options
- Various mast tilt ranges
- Multifunction joystick
- MONOTROL® pedal direction control with direction change interlock system
- Radial and pneumatic-shaped solid tires
- Enclosed cab, with or without air conditioning
- Multiple inside-cabin options
- Multiple seat options
- 3-point high visibility seat belts
- Powered tilting operator compartment for service access
- Visible alarm / amber strobe light
- Various high performance LED (light emitting diode) and halogen light kits available
- Lockable fuel cap
- High mount exhaust
- High mount air intake
- Hydraulic accumulator
- Various traction speed limiters
- Empty seat engine shutdown - adjustable from 3-15 minutes (preset to 15 minutes)
- Lifting eyes
- Steer wheel lug protection
- Engine block heater (110V or 230V)
- Front and rear mud flaps
- H-pattern wiper on front windshield
- Mechanical mast tilt indicator

* For Latin American markets only



Hyster Company
P.O. Box 7006
Greenville, North Carolina
27835-7006
Part No. H360-36/48HD/TG
11/2017 Litho in U.S.A.

Visit us online at www.hyster.com or call us at 1-800-HYSTER-1.

Hyster, , and STRONG PARTNERS. TOUGH TRUCKS. are registered trademarks in the United States and certain other jurisdictions. Cummins, ZF, Kessler and Sy-Klone are registered trademarks of their respective companies. Hyster products are subject to change without notice.

Trucks may be shown with optional equipment. © 2017 Hyster Company. All rights reserved.