



# MPE060F

Rider/Walkie Pallet Trucks  
6,000 lbs

**Yale®** motorized hand trucks incorporate the latest state-of-the-art technology and ergonomics design making Yale the leader for walkie/rider applications.

## Controls

Travel direction and speed are selected by rotating the actuator in the desired direction of travel. The rotary actuator provides multiple grip positions minimizing operator fatigue. The stationary portion of the hand rail minimizes wrist movement and provides a solid grip while maneuvering the truck. The top-mounted handle optimizes operator comfort in the ride position.

**Lift, lower, and horn pushbuttons** are conveniently located on the control handle and hand rail to enable use in the walk or ride position.

## The Traction Reversing Switch

located on top of the handle provides a large area of contact for the operator. When the operator makes contact with the switch the truck simultaneously reverses direction and sounds the horn.

**Optional Power Assist Steer** helps the operator to easily maneuver the truck with heavy loads through congested loading areas. The amount of assist varies based upon control handle position, steer angle and truck travel speed.

**Optional Smart Coast Control with Pick Assist** allows the operator to move the truck forward without having to re-mount the truck and lower the steer handle each time, saving valuable time during pick operations.

## Operator's Compartment

The ergonomically designed hand rail and platform enables operation from either the left or right side. The top-mounted handle and hand rail buttons provide intuitive control of travel, steering, lift/lower and the horn. The hand rail provides a place for the operator to grab when

stepping on to the platform as well as providing stability when driving the truck. The auxiliary controls located on the hand rail are designed to minimize movement of the hand to actuate the various functions. This design adds to operator stability.

The large platform, top-mounted control handle, and contoured covers give the operator maximum workspace. The hand rail and handle grips are designed to fit an operator's natural hand position. A thick cushioned floor mat and padded hand rail absorbs road shock and reduces operator fatigue.

## Electrical System

The electrical system utilizes AC drive technology designed for exceptional performance. High starting torque and smooth acceleration are a few factors benefited from this technology. A speed sensor built into the motor provides feedback to the control system, allowing motor speed and direction to be continuously monitored. The MPE provides industry leading acceleration and a top speed up to 9 mph.

## CANbus Communication

**Technology** streamlines communications between truck systems. The control handle, controller, display and optional power assist steer communicate via the CANbus network. CANbus reduces wiring and electrical connections.

## A Thermal Management System

continuously monitors traction motor and motor controller temperatures, and if necessary, the system gradually adjusts performance to protect truck systems.

## AC Traction System

The traction system consists of the traction motor, gearbox, and brake. The innovative gearbox design incorporates maintenance-free steer bearings, a stationary mounted traction motor, integrated motor pinion, and drive axle string guard. The permanently lubricated steer bearings are sealed within the gearbox housing. The stationary traction motor eliminates power cable tension and flex. The integral pinion and support bearings optimize the gear mesh resulting in a quieter gearbox. The splined coupling allows for quick removal and installation of the traction motor. The drive axle string guard minimizes axle seal damage from shrink-wrap, banding, etc. The electrically released/mechanically applied brake is mounted on the top of the traction motor for ease of inspection and service.

**The on-board software** allows certified personnel access to programming, test and diagnostic functions without the need of a handset or special tools. More in-depth programming can be performed by the servicing dealer using a PC service tool.

*(continued on back)*



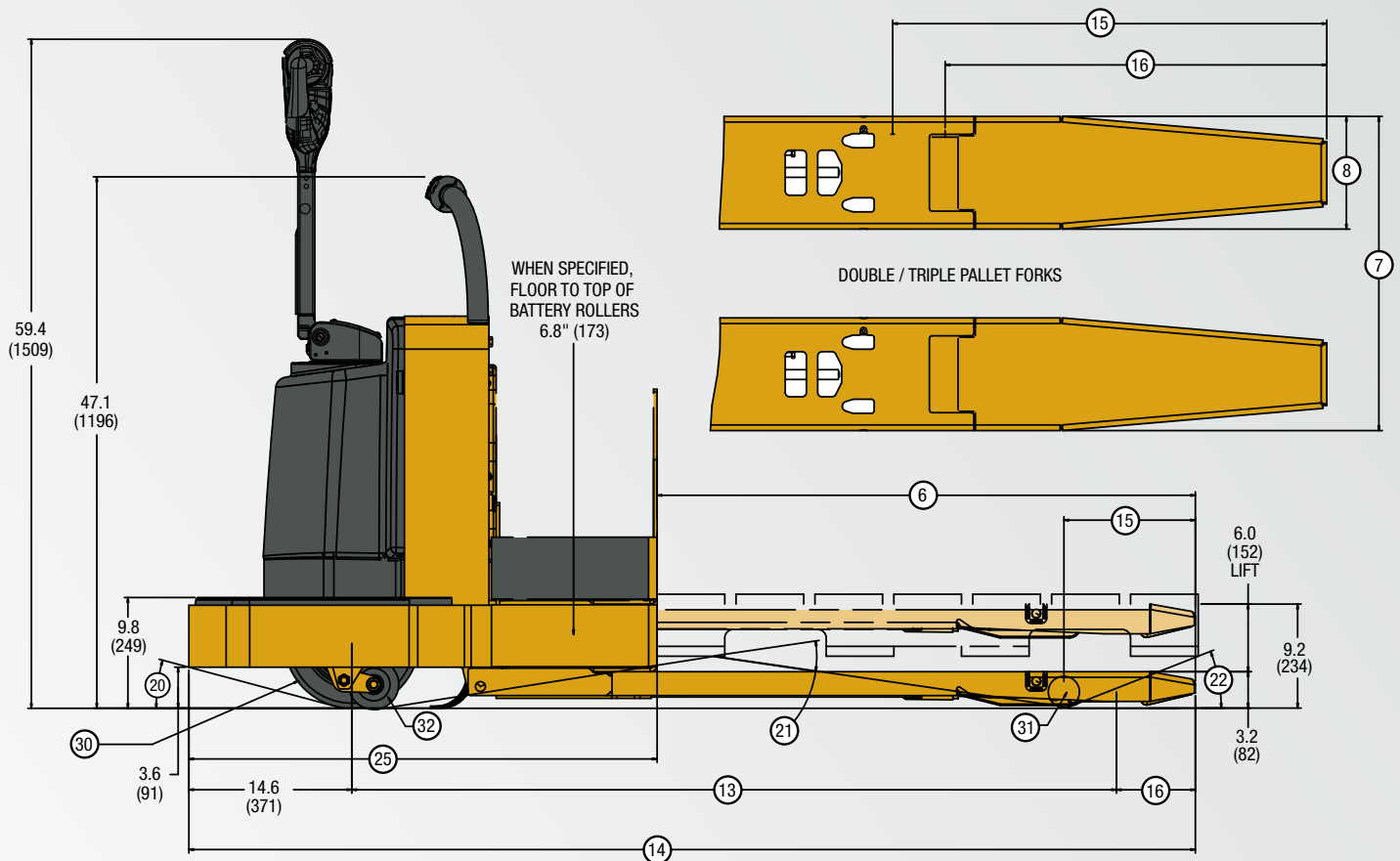
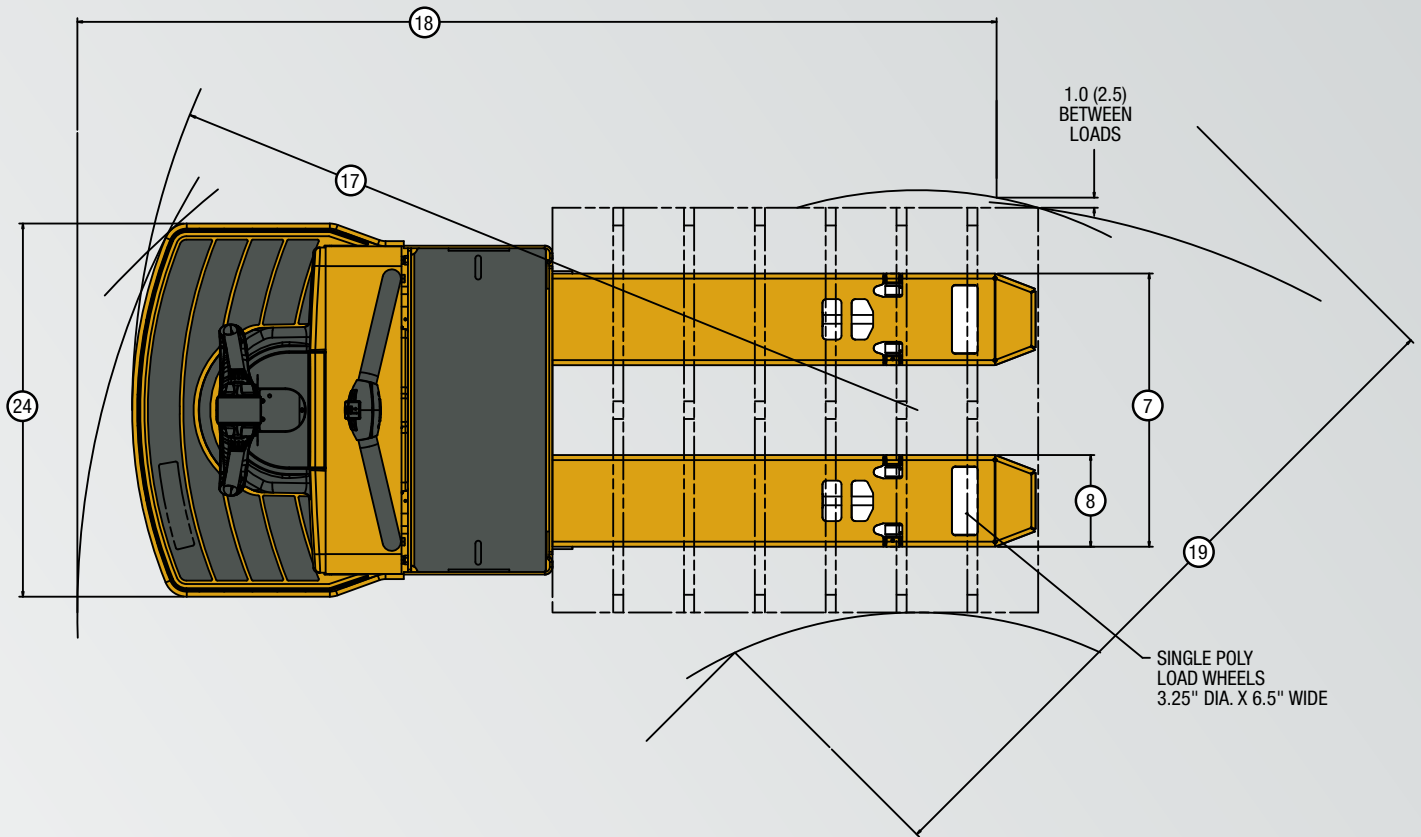

Circled dimensions correspond to the line numbers on the tabulated chart inside the spec sheet. Dimensions are in inches (millimeters).

GENERAL	1	Manufacturer		Yale®				
	2	Model Designation		MPE060F				
	3	Power		Battery - 24 Volt				
	4	Operation		Stand Ride				
	5	Rated Capacity	lb (kg)	6000 (2722)				
	6	Fork Length (Nominal)	in (mm)	36 (914)	42 (1067)	48 (1219)	60 (1524)	
		Fork Length (Actual)	in (mm)	35.75 (908)	41.75 (1060)	47.75 (1213)	59.75 (1518)	
	7	Fork Overall Width	in (mm)	27.0 (686)	27.0 (686)	27.0 (686)	27.0 (686)	
	8	Fork Width (Individual Fork)	in (mm)	9.1 (231)	9.1 (231)	9.1 (231)	9.1 (231)	
	9	Load Distance - Face of Forks to Center of Load Wheel - Lowered	in (mm)	28.75 (730)	34.75 (883)	40.75 (1035)	52.75 (1340)	
WEIGHTS	10	Truck Weight - Without Battery - No Load	lb (kg)	1237 (561)	1257 (570)	1272 (577)	1302 (591)	
	11	Axle Loading	Drive Static with Max. Wt. Battery - Rated Load	lb (kg)	2268 (1029)	2566 (1164)	2807 (1273)	3212 (1457)
			Drive Static with Max. Wt. Battery - No Load	lb (kg)	1541 (699)	1601 (726)	1649 (748)	1760 (798)
	12		Load Wheel Static with Max. Wt. Battery - Rated Load	lb (kg)	6109 (2771)	5831 (2645)	5605 (2542)	5230 (2372)
			Load Wheel Static with Max. Wt. Battery - No Load	lb (kg)	836 (379)	796 (361)	763 (346)	682 (309)
DIMENSIONS	13	Wheelbase	No Load Backrest or w/ Pivoting Load Backrest - Raised	in (mm)	49.2 (1250)	55.2 (1402)	61.2 (1554)	73.2 (1859)
			No Load Backrest or w/ Pivoting Load Backrest - Lowered	in (mm)	53.8 (1367)	59.8 (1519)	65.8 (1671)	77.8 (1976)
			With Bolt-On Load Backrest - Raised	in (mm)	51.2 (1300)	57.2 (1453)	63.2 (1605)	75.2 (1910)
			With Bolt-On Load Backrest - Lowered	in (mm)	55.8 (1417)	61.8 (1570)	67.8 (1722)	79.8 (2027)
	14	Overall Length	No Load Backrest or w/ Pivoting Load Backrest	in (mm)	75.3 (1913)	81.3 (2065)	87.3 (2217)	99.3 (2522)
			With Bolt-On Load Backrest	in (mm)	77.3 (1963)	83.3 (2116)	89.3 (2268)	101.3 (2573)
	15	Center of Load Wheel to Tip of Forks - Raised		in (mm)	11.7 (297)	11.7 (297)	11.7 (297)	11.7 (297)
	16	Center of Load Wheel to Tip of Forks - Lowered		in (mm)	7.0 (178)	7.0 (178)	7.0 (178)	7.0 (178)
	17	Outside Turning Radius	No Load Backrest or w/ Pivoting Load Backrest - Raised	in (mm)	63.6 (1615)	69.6 (1768)	75.6 (1920)	87.6 (2225)
			No Load Backrest or w/ Pivoting Load Backrest - Lowered	in (mm)	68.3 (1735)	74.3 (1887)	80.3 (2040)	92.3 (2344)
			With Bolt-On Load Backrest - Raised	in (mm)	65.6 (1666)	71.6 (1819)	77.6 (1971)	89.6 (2276)
			With Bolt-On Load Backrest - Lowered	in (mm)	70.3 (1786)	76.3 (1938)	82.3 (2090)	94.3 (2395)
	18	Right Angle Stack	No Load Backrest or w/ Pivoting Load Backrest - Raised	in (mm)	78.6 (1996)	83.7 (2126)	89.1 (2263)	100.0 (2540)
			With Bolt-On Load Backrest - Raised	in (mm)	80.4 (2042)	85.4 (2169)	90.9 (2309)	101.8 (2586)
	19	Equal Intersecting Aisle	No Load Backrest or w/ Pivoting Load Backrest - Raised	in (mm)	61.8 (1570)	64.9 (1648)	68.0 (1727)	74.3 (1887)
			With Bolt-On Load Backrest - Raised	in (mm)	63.3 (1608)	66.5 (1689)	69.6 (1768)	75.9 (1928)
	20	Grade Clearance - Chassis		%	26	26	26	26
	21	Grade Clearance - Center of Wheelbase		%	39	34	31	25
	22	Grade Clearance - Forks		%	39	39	39	39
	23	Lift Height - Top of Fork - Lowered / Raised / Total Lift	in (mm)		3.2 / 9.2 / 6.0 (81 / 234 / 152)			
24	Truck Overall Width	in (mm)		36.9 (937)				
25	Chassis Length - Length to Face of Forks	in (mm)		39.5 (1003)				
26	Battery Compartment - Length x Width x Height - Std / w/Battery Rollers	in (mm)		31.25 x 13.4 x OPEN (794 x 340 x OPEN)				
PERF.	27	Travel Speed - Chassis First - No Load / Rated Load	mph (kph)	9.0 / 6.7 (14.5 / 10.8)				
		Travel Speed - Forks First - No Load / Rated Load	mph (kph)	6.0 / 5.2 (9.7 / 8.4)				
	28	Drive Control Type		AC				
29	Service Brake Type		Electro-Mechanical					
WHEELS	30	Drive Tire - Size / Type (Number of Wheels)	in	10.0 x 5.0 x 6.5 / Poly (1)				
	31	Load Wheel - Size / Type (Number of Wheels)	in	3.25 x 6.5 / Poly (2)				
	32	Caster Tire - Size / Type (Number of Wheels)	in	4.0 x 2.5 / Poly - Spring Loaded (2)				

Above specifications, unless otherwise listed, are for a standard truck without optional equipment.  
Right Angle Stack and Equal Intersecting Aisle are calculated using a 40" wide pallet.  
Grade Clearance measured to the bottom of the pallet with forks in a raised position.

BATTERY SPECIFICATIONS							
Number of Cells	Cell Size	Plates per Cell	Capacity 6 Hour Rate amp hr (kwh)	Battery Dimensions			Weight lb (kg)
				"X"	"Y"	"Z"	
				in (mm)	in (mm)	in (mm)	
12	75	7	225 (5.2)	25.7 (652)	8.8 (224)	23.3 (592)	540 (245)
12	85	7	255 (6.0)	25.7 (652)	8.8 (224)	23.3 (592)	570 (259)
12	75	11	375 (8.7)	26.5 (673)	13.0 (330)	23.3 (592)	825 (374)
12	85	11	425 (9.9)	26.5 (673)	13.0 (330)	23.3 (592)	865 (392)
12	75	13	450 (10.5)	30.9 (785)	13.0 (330)	23.3 (592)	987 (448)
12	85	13	510 (11.9)	30.9 (785)	13.0 (330)	23.3 (592)	1035 (469)
12	100	13	600 (14.0)	30.9 (785)	13.0 (330)	26.2 (665)	1200 (544)

Battery Connector: 175 Amp, Red  
 Battery Lead: Length 20" (508 mm), Position "B", 1/0 AWG

(continued from cover)

Certified technicians can customize the performance of the truck to meet the customer's particular application. The truck features four operator selectable modes, as well as two master level performance settings.

### Hydraulic Components

The high performance hydraulic system is designed for high cycle, multi-shift operations. The hydraulic pump and motor assembly features a series wound motor which provides high torque and low noise. The translucent tank provides quick and easy inspection of hydraulic oil level.

### Forks and Frame

Robotically welded steel forks are formed and fabricated for strength and rigidity. The 1" x 2" pull rods and replaceable threaded ends allow for easy fork adjustment. Pull rod adjustment can be easily made from the top of the fork.

### Pallet Entry and Exit

Yale fork design provides industry leading pallet entry and exit of both standard and non-standard pallets. The pallet entry/exit system consists of a tapered fork nose, exit runners, and a center roller.

### Wheels, Tires, and Casters

A 10" drive tire is used on the MPE060F. The drive wheel is secured to the drive axle with five bolts. Single load wheels (3.25" x 6.5") are standard on all trucks. A knock-out axle provides access for quick and easy maintenance. Two spring-loaded casters provide additional stability.

### Options

- Power assist steer
- Heavy duty casters
- Battery rollers
- Convenience tray (load backrest mounted or battery mounted)
- RF terminal power supply – 24-volt, unregulated
- Audible alarm
- Visible alarm – pole mounted amber strobe
- Fork lengths:
  - 36" long forks
  - 42" long forks
  - 60" long forks
- Drive tire:
  - Rubber – 65 durometer – 10" x 5.0"
  - Siped polyurethane – 90 durometer – 10" x 5.0"
- Load wheels – various options available
- Load backrest:
  - 48" high (pivoting or bolt-on)
  - 60" high (pivoting or bolt-on)
  - 72" high (bolt-on)
- Accessories:
  - Manual coast control with pick assist
  - Smart coast control with pick assist
  - Application / environmental construction:
    - Cooler/Freezer Package (operating temperatures: 0° F to +120° F)
    - SubZero Freezer Package (operating temperatures: -40° F to +120° F)



YALE MATERIALS HANDLING CORPORATION

P.O. Box 7367, Greenville, NC 27835-7367

www.yale.com

Yale is a Registered Trademark and  is a Registered Copyright.  
 ©Yale Materials Handling Corporation 2014. All Rights Reserved.

Manufactured in our own ISO 9001 and 14001 Registered Facilities

2544-1B 6/2014 All trucks shown with optional equipment.

Truck performance may be affected by the condition of the vehicle, how it is equipped and the application. Consult your Yale® Industrial Truck Dealer if any of the information shown is critical to your application. Specifications are subject to change without notice.

This truck meets all applicable mandatory requirements of ANSI B56.1 Safety Standard for Powered Industrial Trucks at the time of manufacture. Classified by Underwriters' Laboratories, Inc., as to fire and electric shock hazard only for Type E industrial trucks.

The Yale® products included in this document may be covered by US patent 6,684,148 and other patents pending.