

Ranger DX800

Surface Top Hammer Drills



Ranger DX800 is a hydraulic, self-propelled, self-contained, crawler based surface drilling rig equipped with a cabin (F.O.P.S. and R.O.P.S.) and rod handling system.

Typical applications for DX800 are road cutting, pipe-line drilling and foundation drilling, as well as production drilling in medium size quarries. Therefore DX800 is most often used by construction contractors, mines and quarries, and also included in the equipment fleet of rental houses as well.

Hole Diameter:	76 - 127 mm (3" - 5")
Rock Tools:	45 or 51 mm (1 ¾" and 2") rods
Rock Drill:	21/23kW
Engine Output:	168 kW
Flushing Air:	8.1 m ³ /min, up to 10 bar
Production Capacity:	1,3 Mt/year
Total Weight	15 600 kg

STANDARD COMPONENTS

Rock drill	HL810T , hydraulic
Chain feed	CF 145H, with hose reel
Rod handler	RH 714 incl. 1 set of jaws
Boom	DB 800H, articulated
Carrier	Track mounted, turnable superstructure
Powerpack	Diesel driven, hydraulic pumps and on-board compressor
Hydraulic system	Load sensing and open center
Control system	Rock Pilot+
Movable drill steel support	
Cabin	F.O.P.S. and R.O.P.S.and Air conditioning
Dust collector	DC 810 H, hydraulic Primary separator
Working lights	9 pcs
Gauge set	For accumulator pressure checking
EU-safety devices	EN 16228, service light, alarm signal, alarm beacon
Manuals	1 x paper copy 1 x CD-ROM (ToolMan)

THE JAWS FOR DRILL STEELS

Drill steel type	Drill steel diameter	Recommended hole diameter
Extension rods	45 mm 1 ¾"	76 - 89 mm 3" - 3 ½"
MF-rod	45 mm 1 ¾"	76 - 89 mm 3" - 3 ½"
MF-rod	51 mm 2"	89 - 127 mm 3 ½" - 5"
Extension rods	51 mm 2"	89 - 127 mm 3 ½" - 5"

Note: not with 10' MF-rods. With hose reel only 10' or 12' rods. 51 mm (2") extension rods only 5 + 1. If several jaws selected please specify jaws assembled

SELECTION OF OPTIONS

1.	Turnable superstructure 180 deg.
2.	HF 810T rock drill
3.	Alternative seat ISRI 6000
4.	Radio and CD-MP3 player
5.	Reversing camera
6.	Vacuum cleaner for cabin
7.	TIM 5200 for vertical holes
8.	TIM 5300 for vertical holes and depth measuring
9.	TIM 6300 for inclined holes and depth measuring
10.	TIM 6500 for inclined holes, depth measuring and laser level (double receiver)
11.	TIM 6700 with interface to external navigation system
12.	GPS aiming device for TIM 6300 and TIM 6500
13.	TIM3D navigation system
14.	Power extractor
15.	Readiness for Power Extractor
16.	Horizontal drilling kit including hose reel
17.	Thread greasing
18.	1. Thread greasing with 5 gallon bucket
19.	Anti- freeze system for air lines
20.	Flushing control automatics
21.	Shut down of suction for water holes
22.	Water injection system
23.	Guides for grousers
24.	Dustmizer
25.	Three bar grouser plates
26.	Towing hook
27.	Xenon lights, 6 pcs
28.	Hydraulic rear ground support
29.	Winch with radio remote control and cable tightness automatics
30.	Radio remote control for rear ground support, tramming and oscillation
31.	Fuel powered heater for engine and cabin
32.	Fuel powered heater for engine, cabin and water tank
33.	Readiness for fuel powered heater
34.	Electric fuel filling pump
35.	Grinder Sandvik RG420H
36.	Central lubrication system Sandvik
37.	Biogradeable hydraulic oil, Shell Naturelle HFE 46 or HFE 68
38.	Kit for alternative steels, each
39.	First service kit for DX800
40.	Special tools for HL/HF810T, field kit
41.	Special tools for HL/HF810T, complete
42.	Extra manuals
43.	Security+ Silver, Gold or Platinum
44.	SanRemo (Silver, Gold or Platinum)
45.	Winch with full radio remote for drilling, tramming boom and rod handling control
46.	Full radio remote control for drilling tramming boom and rod handling control
47.	LED lights not with laser

COVERAGE AREA

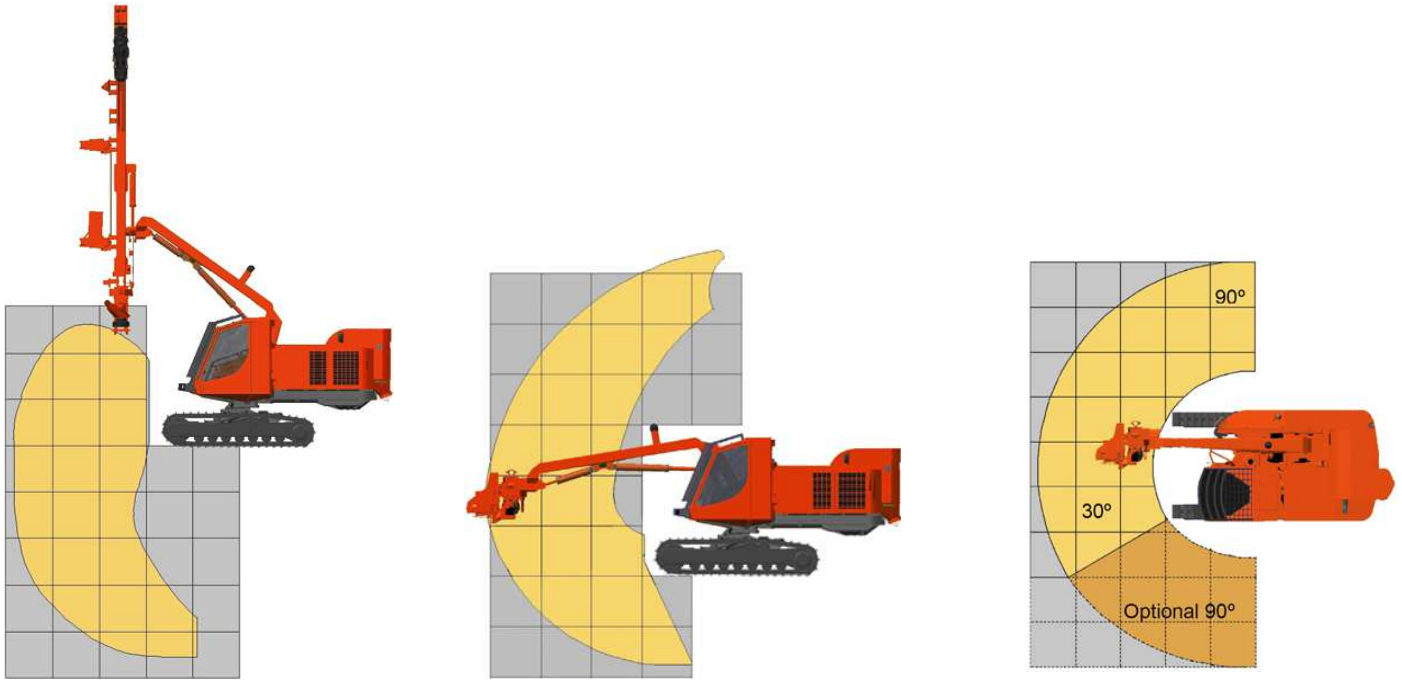

TRAMMING AND TRANSPORT DIMENSIONS

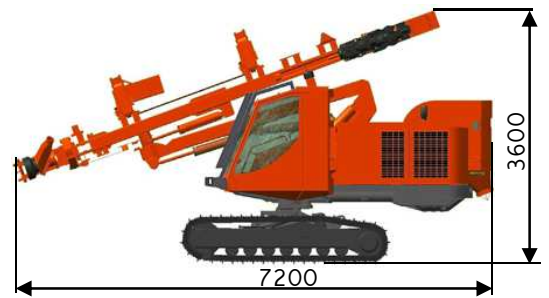
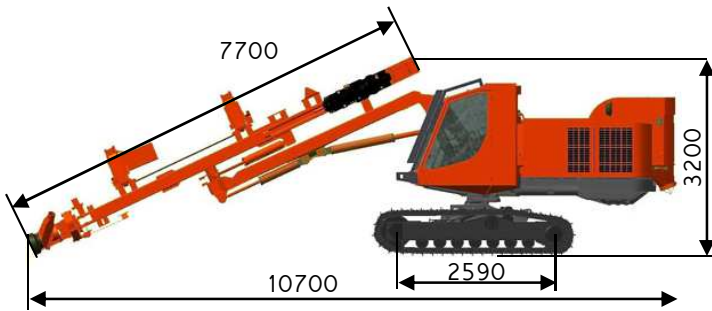

Weight (without options)	15 600 kg
Width	2.45 m
Height	3.6 m / 3.2 m
Total length	7.2 m / 10.7 m

Sandvik Mining and Construction reserves the right to change this specification without further notice.

Sandvik Mining and Construction Oy
 P.O.Box 100, FIN-33311 Tampere, Finland
 Tel. +358 205 44 121, Telefax +358 205 44 4771
www.sandvik.com